



Workshop Five - Building Components

Article 3

06.01.20 - ZAP Committee



Presentation Tonight

- **Part I: Article 3 Schedule**
- **Part II: Deep dive into Building Components**
 - **Goals**
 - **Comparison to De Minimus**
 - **Issues/Solutions to Current Draft**
 - **Discussion**
- **Part III: Responses to Councilor Questions on 5/19 Meeting**



Part I: Article 3 Schedule



Goals

- **Adopt new Zoning Ordinance by end of City Council Term (2021)**
- **Hold a straw vote on each Article as they are reviewed**

Schedule- June

June – 1	June – 15	June – 29
ZAP	ZAP	ZAP
Workshop 5 – Building Components	Workshop 6 – Uses, Parking, Alternate Lot Configurations	Workshop 7 – Revised standards (districts, components, building types)

- **Updated website**
- **Office hours (2)**
- **Professional focus group (2)**
- **Internal working group (2)**

Schedule- July

July – 13	July – 27
ZAP	ZAP
Workshop 8 – Residence Districts zoning map	Workshop 9 – Design/Building professionals discussion

- **Office hours (2)**
- **Professional focus group (2)**
- **Internal working group (2)**

Schedule- August

August – 10	August – 20	August – 24
ZAP	Committee of the Whole	ZAP
Editing and review session I	Article 3 presentation	Editing and review session II

- **Office hours (2)**
- **Professional focus group (2)**
- **Internal working group (2)**

Schedule - September

September – 14	September 30*
ZAP	ZAP
“Public hearing” on Article 3	Straw vote on Article 3

- **Neighborhood Area Councils (4)**
- **Office hours (2)**
- **Professional focus group (2)**
- **Internal working group (2)**

Discussion: Schedule



Part II: Building Components

Goals

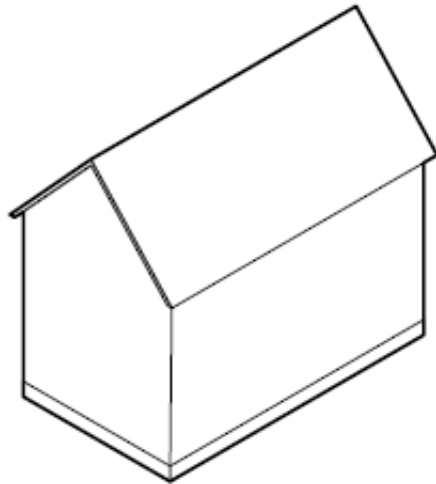

MAIN MASSING of a BUILDING

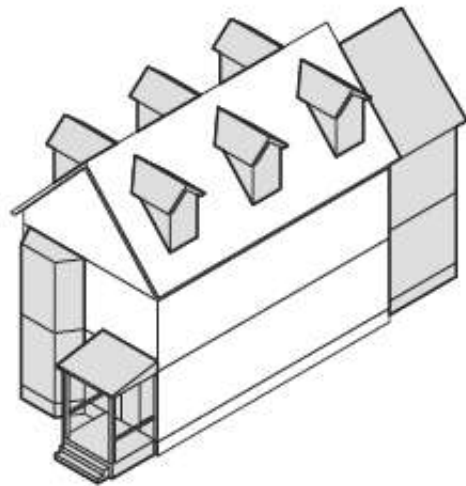

Additional BUILDING COMPONENTS

- **Predictable growth for homeowners and neighbors**
- **Better process for allowing increase in habitable space**
- **Achieve variety and individuality in design**

Goals of Building Components

Reduce Oversized, Boxy rebuilds



Building Components in Newton

Projecting Front Entry



Building Components in Newton Bay



Building Components in Newton Balcony



Building Components in Newton

Front Porch



Building Components in Newton

Turret/ Corner Feature



Building Components in Newton

Dormer



Building Components in Newton

Cross Gable



Building Components in Newton

Roof Deck



Building Components in Newton

Side and Rear Additions

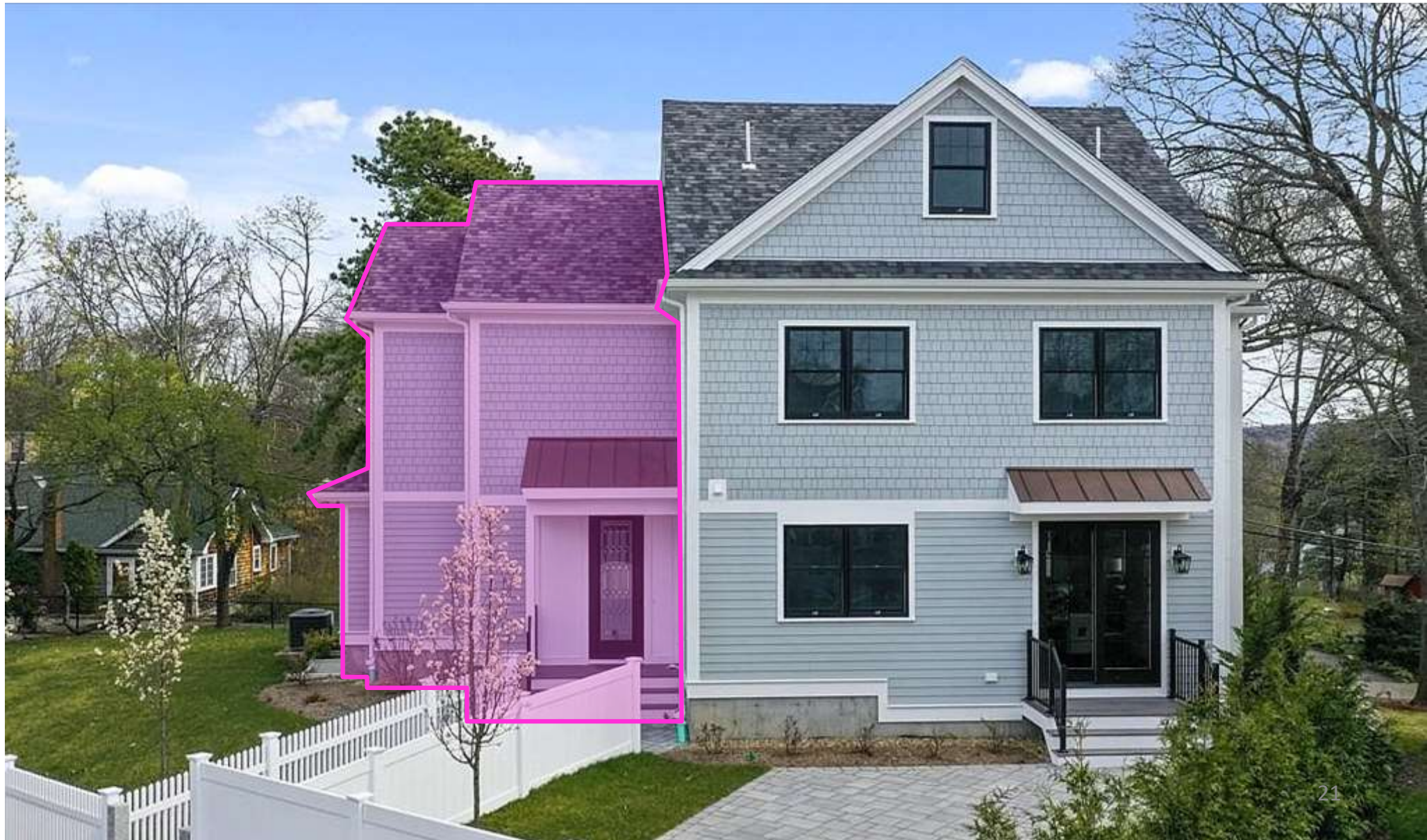

Building Components: A Refinement to De Minimus

Current Code: De Minimis Relief Existing Non-Conforming Building

- SR2
- Over maximum lot coverage of 30%
- Over rear setback

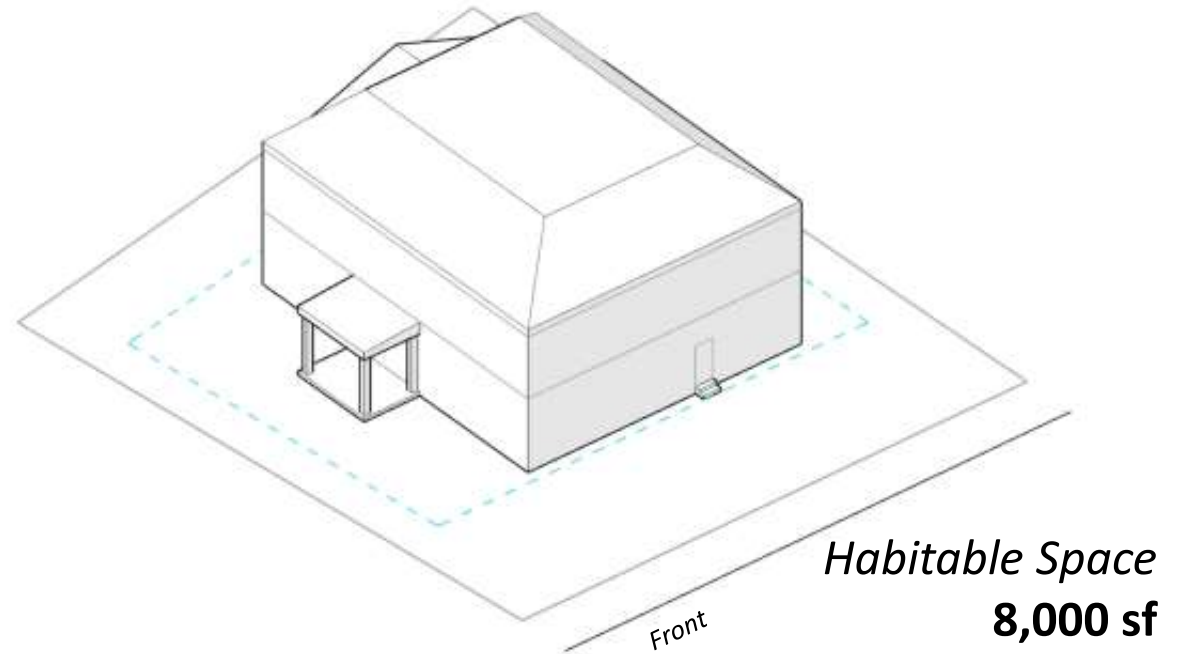
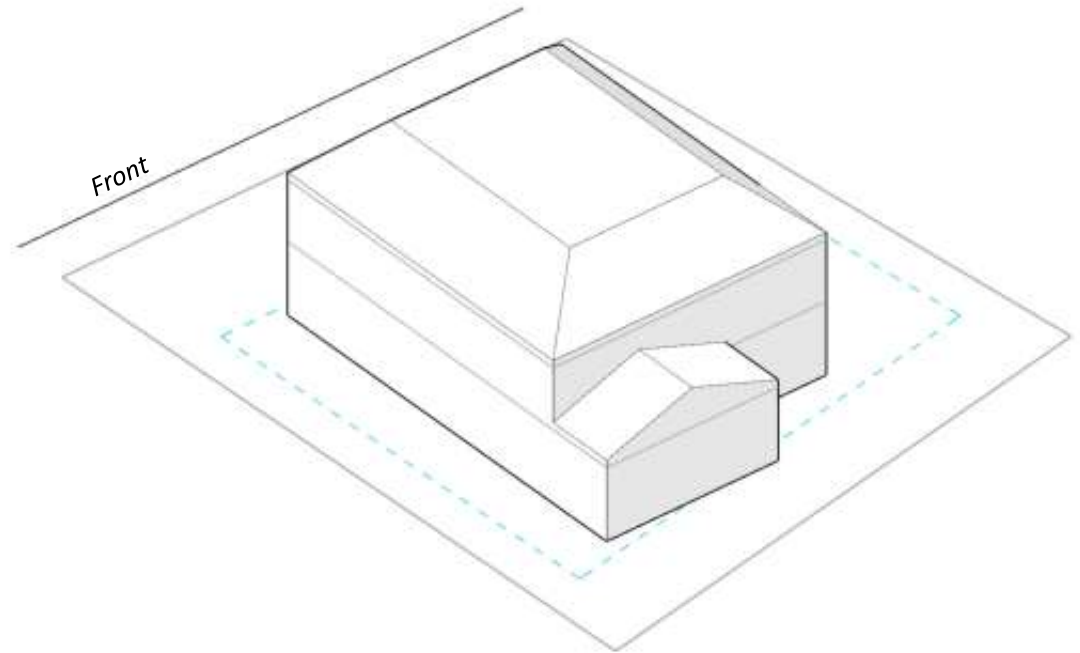
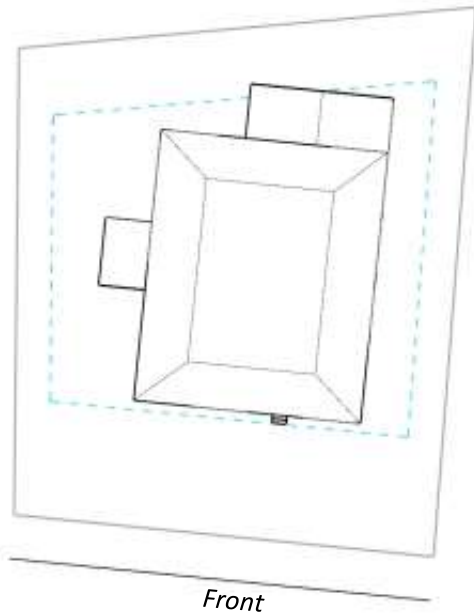

Current Code: De Minimis Relief Dormers

2. *In accordance with Sec. 7.8.2.B.1, the following de minimus alterations are allowed:*
 - a. Dormers that do not extend above the height of the existing roof peak and do not add more than 400 square feet of floor area;

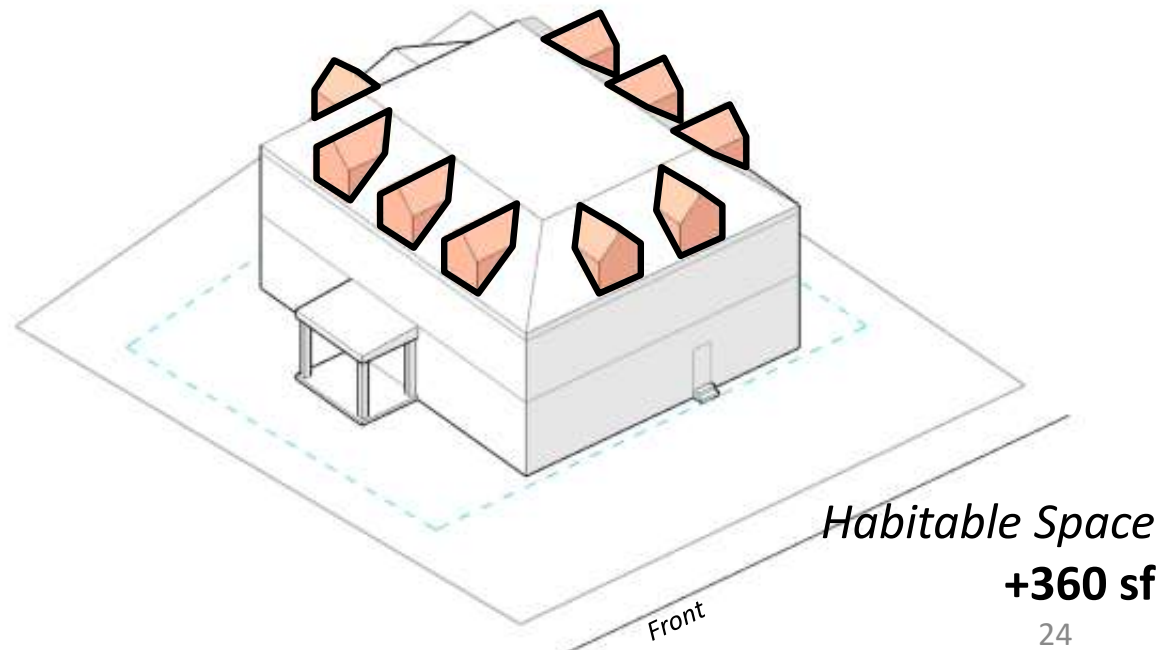
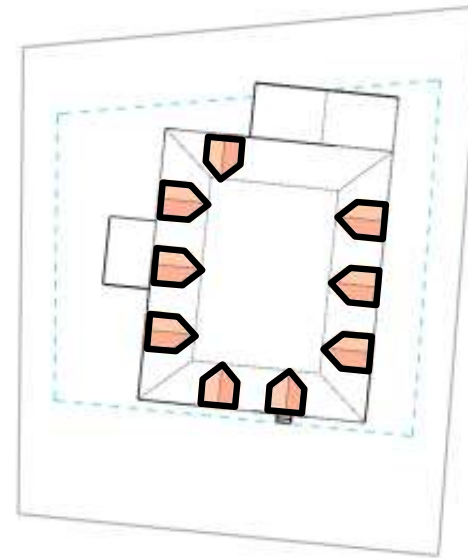

Current Code: De Minimis Relief Second Floor Additions

- d. Second floor additions which do not total more than 400 square feet in size;

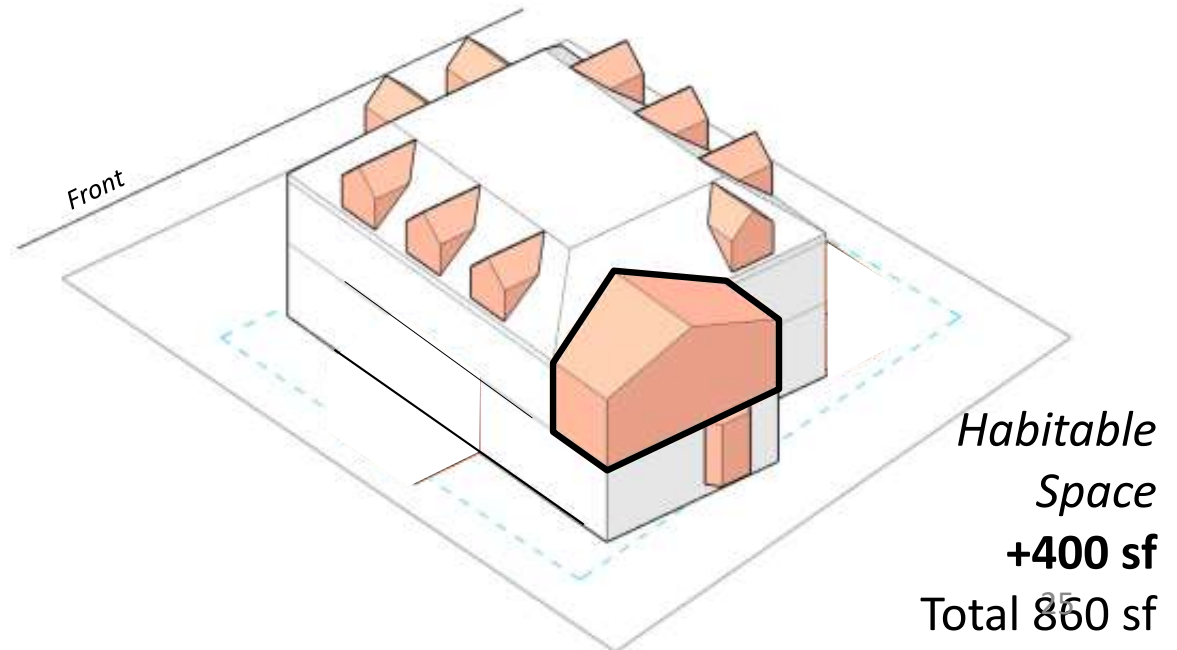
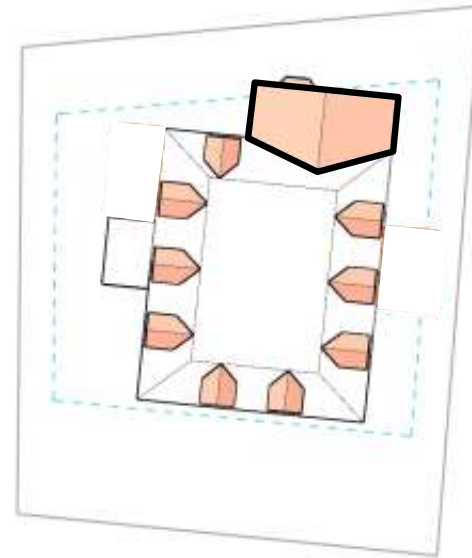

Current Code: De Minimis Relief Enclosing an Existing Porch

- e. Enclosing an existing porch of any size;

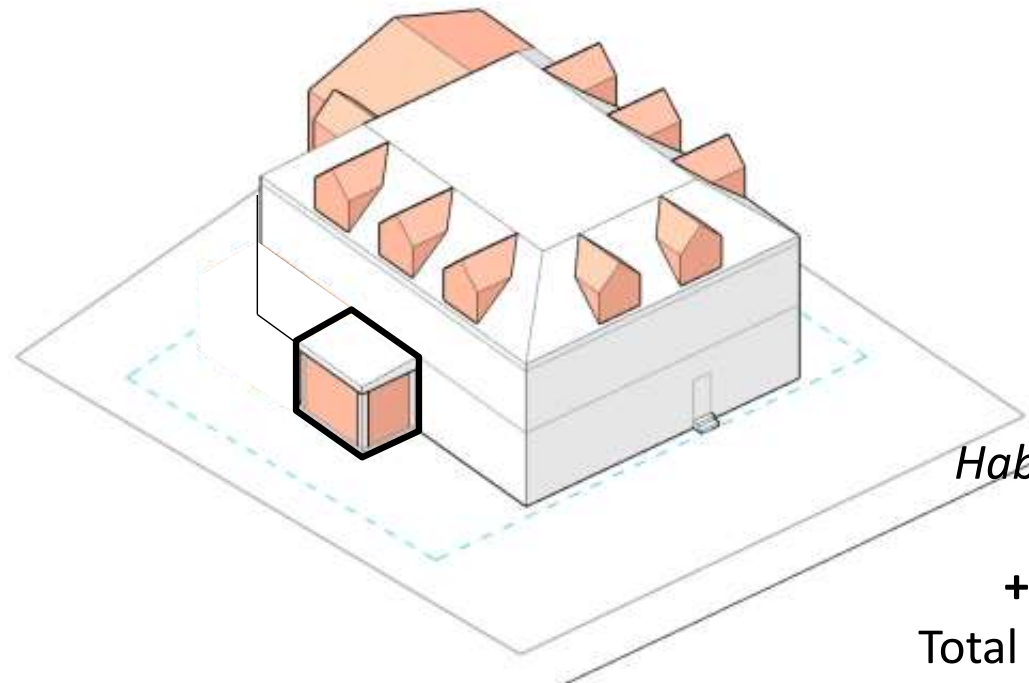
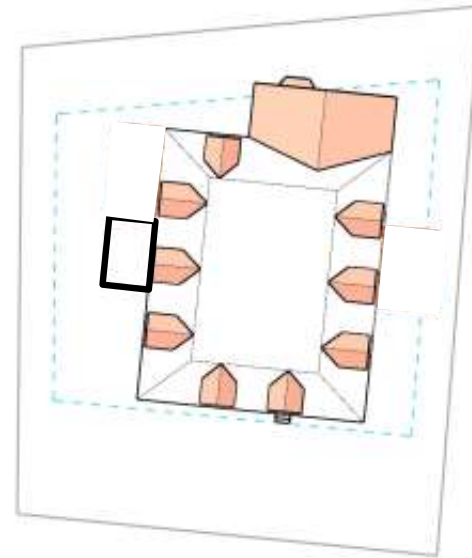

*Habitable
Space*
+145 sf
Total 875 sf

Current Code: De Minimis Relief

Bay windows in Side/ Rear Setbacks

- f. Bay windows in the side and rear setbacks which are cantilevered and do not have foundations;

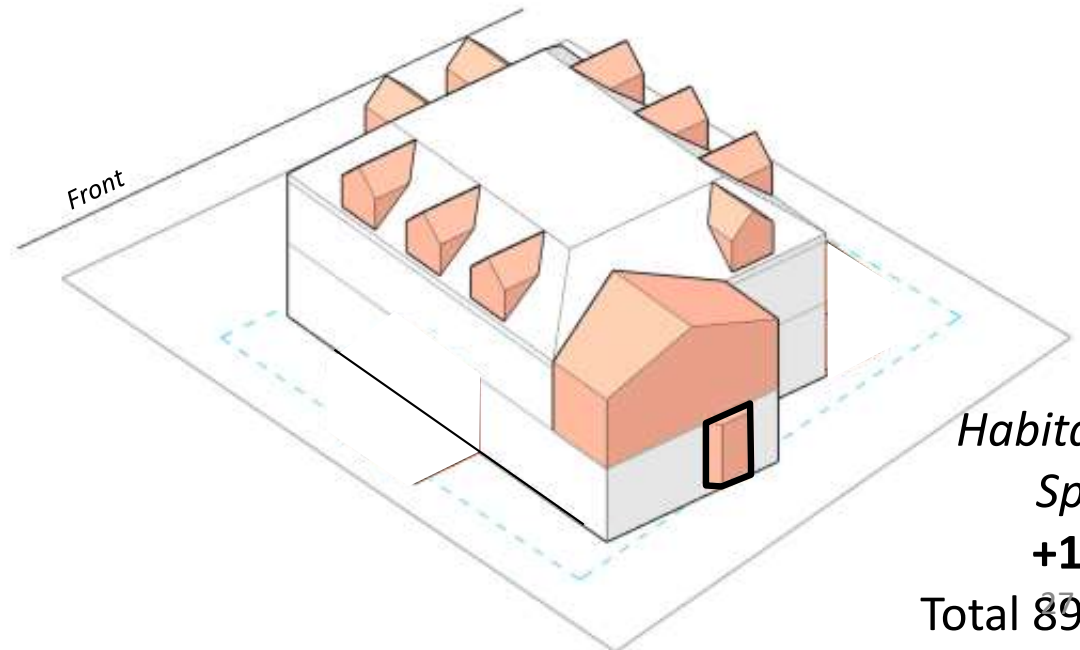
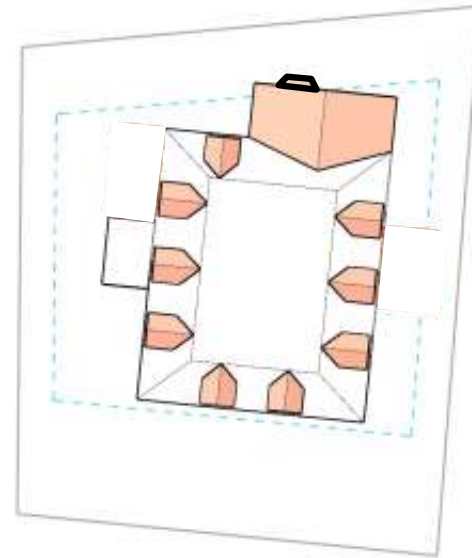

*Habitable
Space
+15 sf
Total 890 sf*

Current Code: De Minimis Relief Bay Windows in Front Setback

- g. Bay windows which protrude no more than 3 feet into the front setback and are no less than 5 feet from the alteration to the lot line;

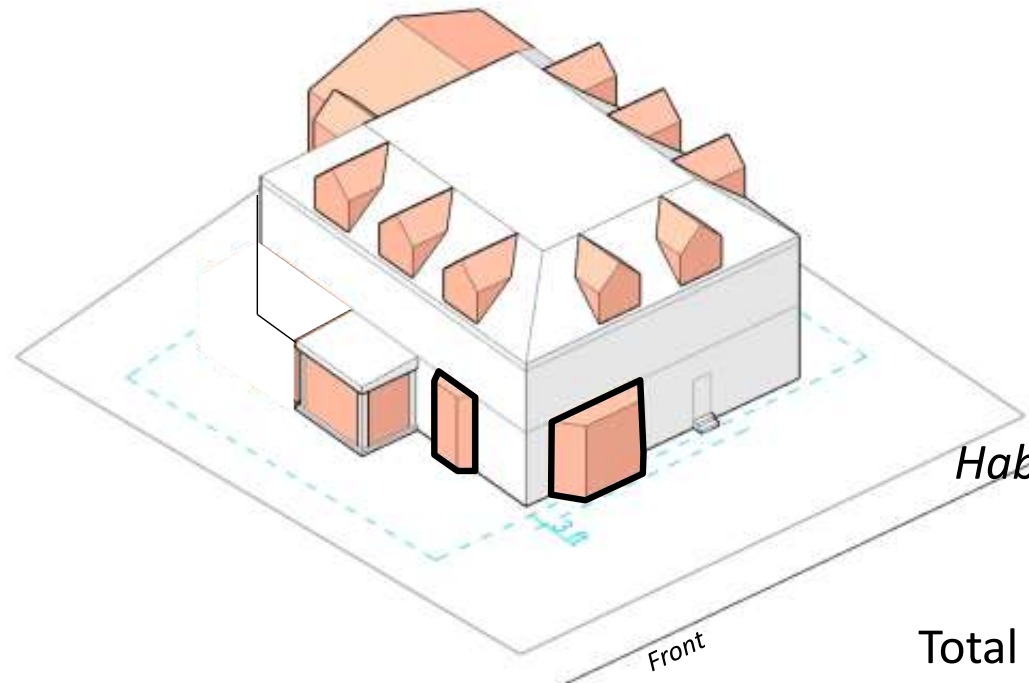
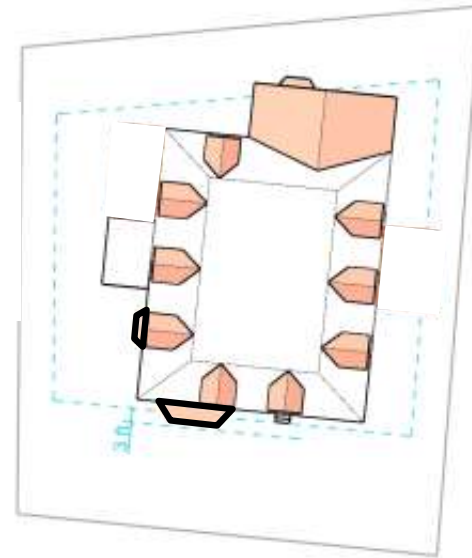

*Habitable
Space
+65 sf*
Total 955 sf

Draft Code: Building Components Follow Logic of De Minimis Relief

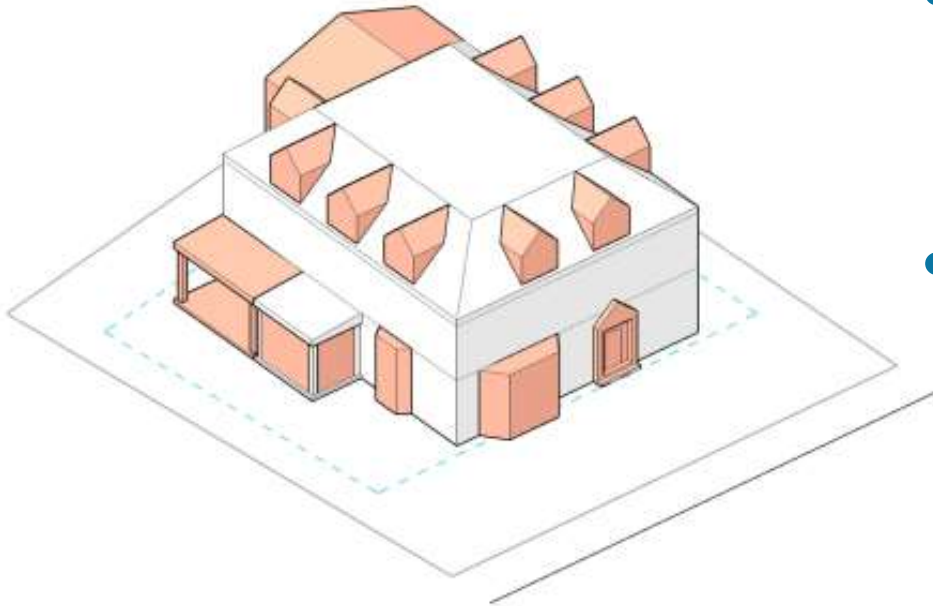

- **Build from the idea of the De Minimis Relief.**
- **Allow by-right renovations/additions in a regulated and predictable manner.**

Issues with Draft Language
&
Recommended Proposed Changes

Problem A

Building Components Count towards Building Type Footprint (sec. 25.1.B)

Less Incentive to use building components



Solution A

Building Components do not count towards Building Type Footprint

More Incentive to use building components

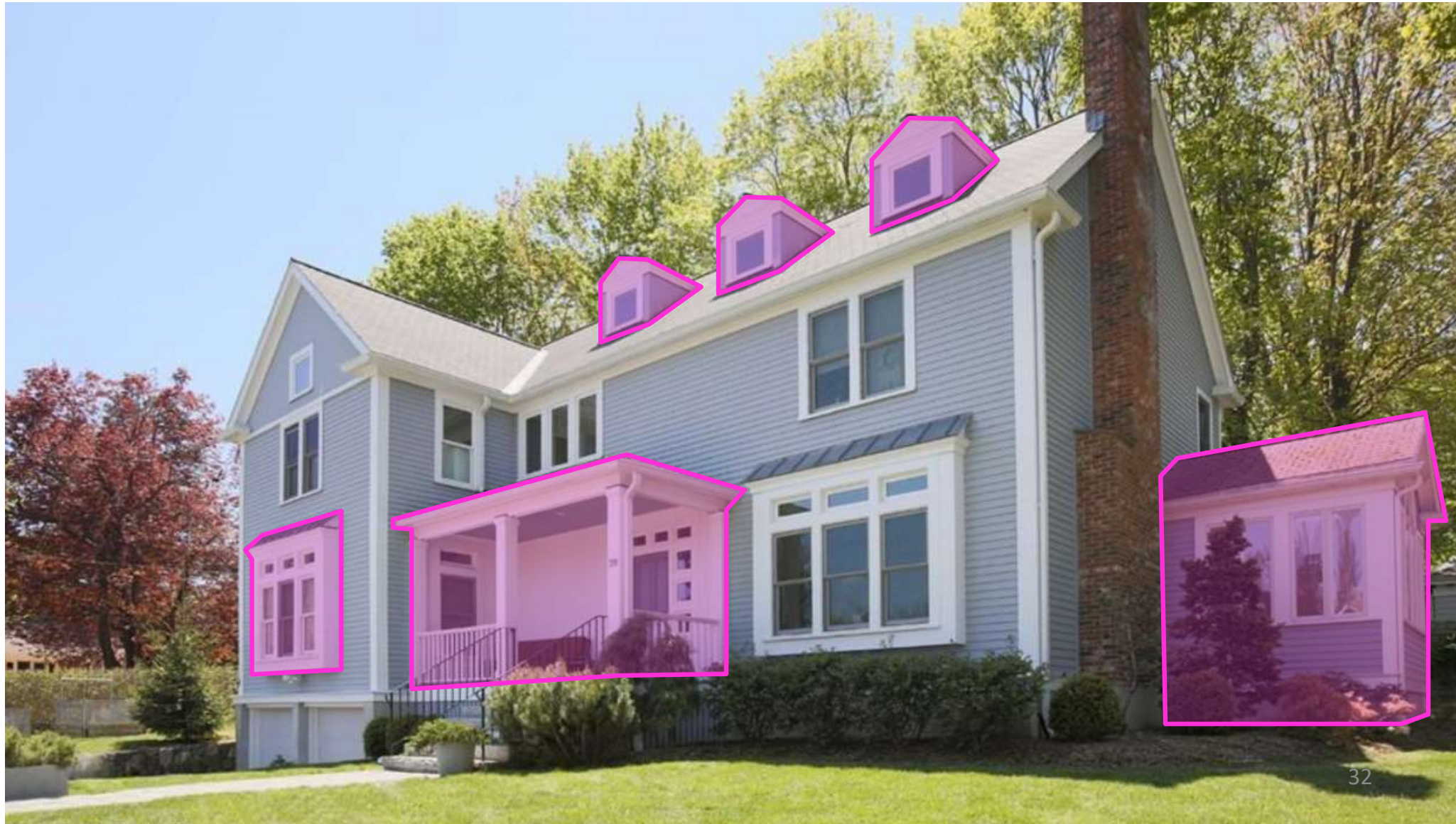

Solution A

Building Components do not count towards Building Type Footprint

More Incentive to use building components

- **Components allowed by-right only when:**
 - **Within setbacks**
 - **Comply with lot coverage**

Problem B

Language too directly implies style

“We don’t want to impose an absolute style”

“Architects need to create vitality and individual expression of unique buildings”

“How do we allow for innovation?”

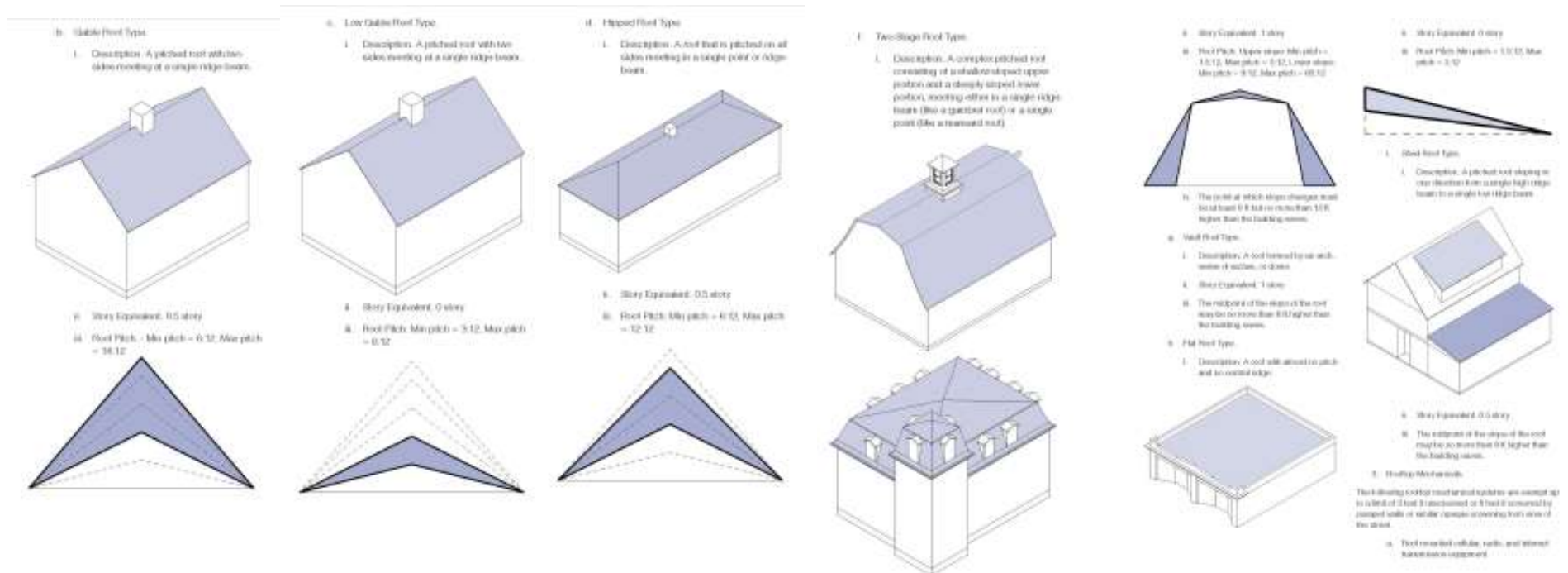

Solution B

Modify regulations so that they allow for a variety of design styles

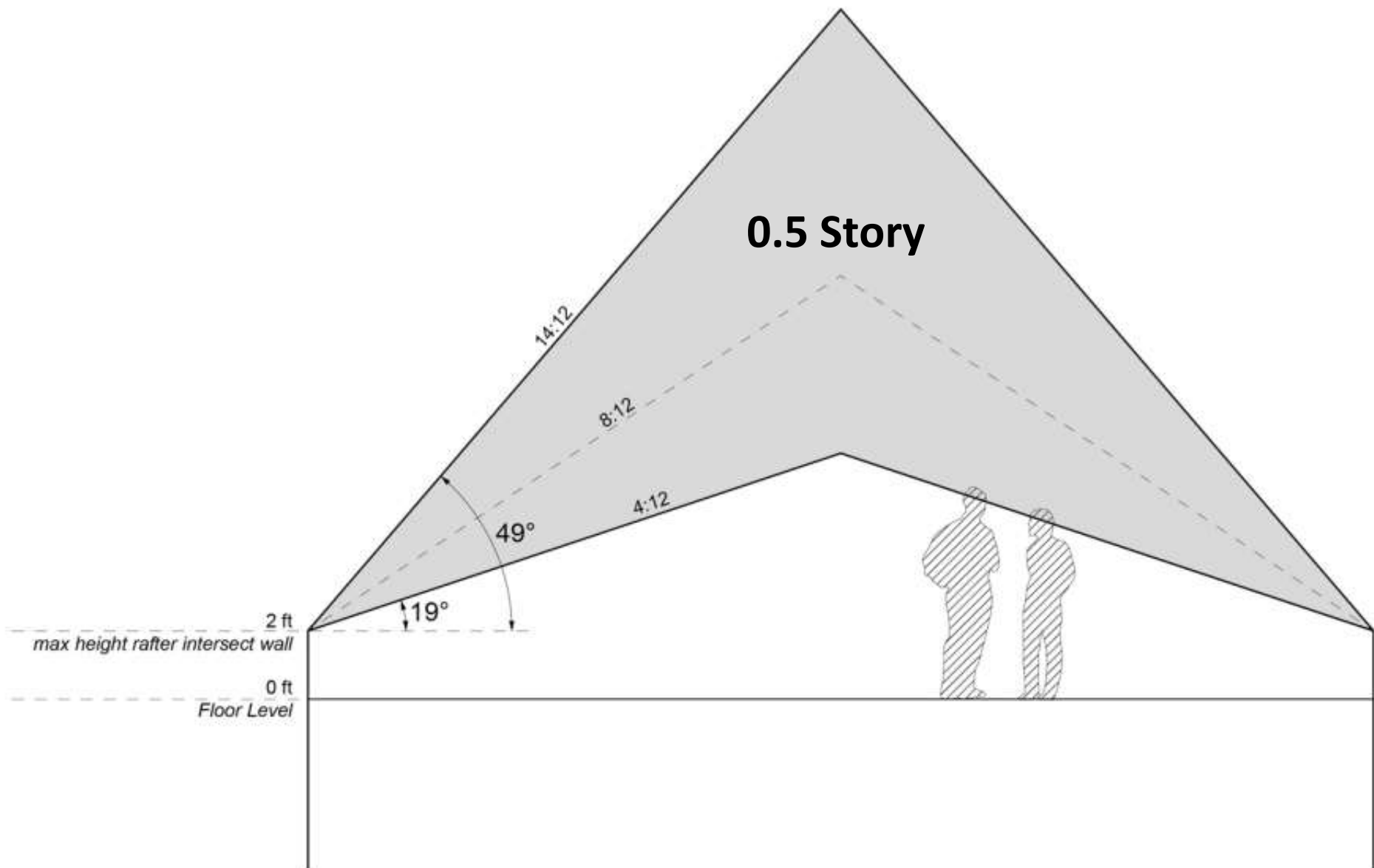

Solution B

Modify regulations so that they allow for a variety of design styles

A few design options for 0.5 story:

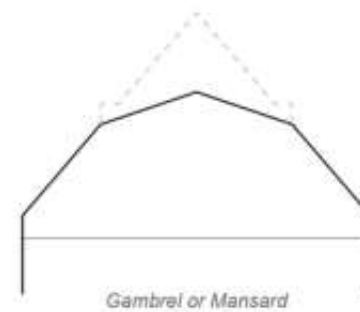
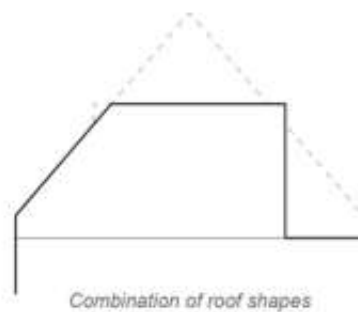
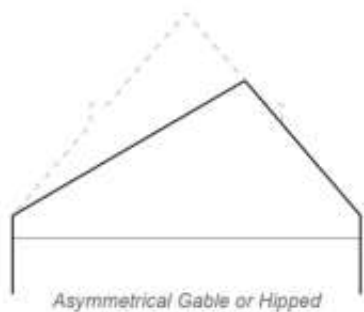
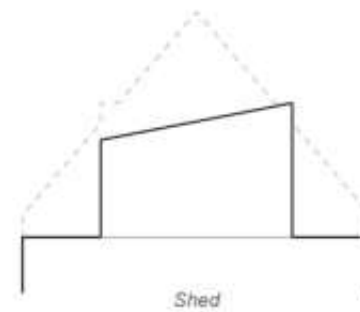
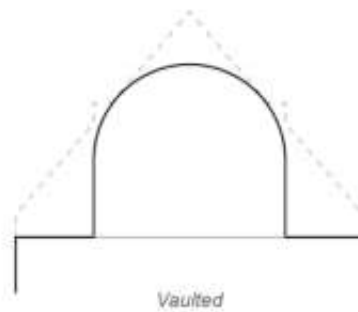
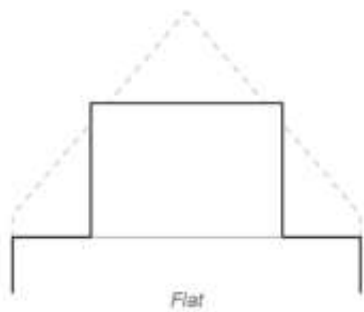
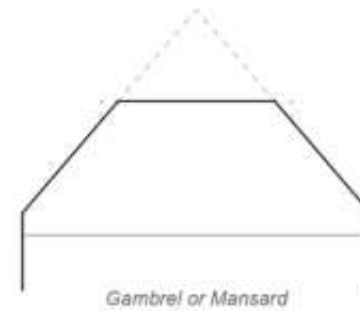
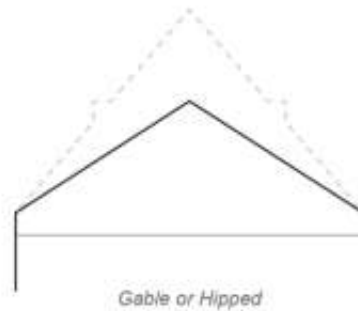
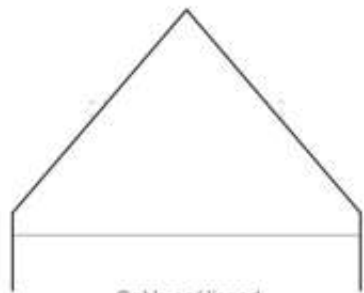

Solution B

Modify regulations so that they allow for a variety of design styles

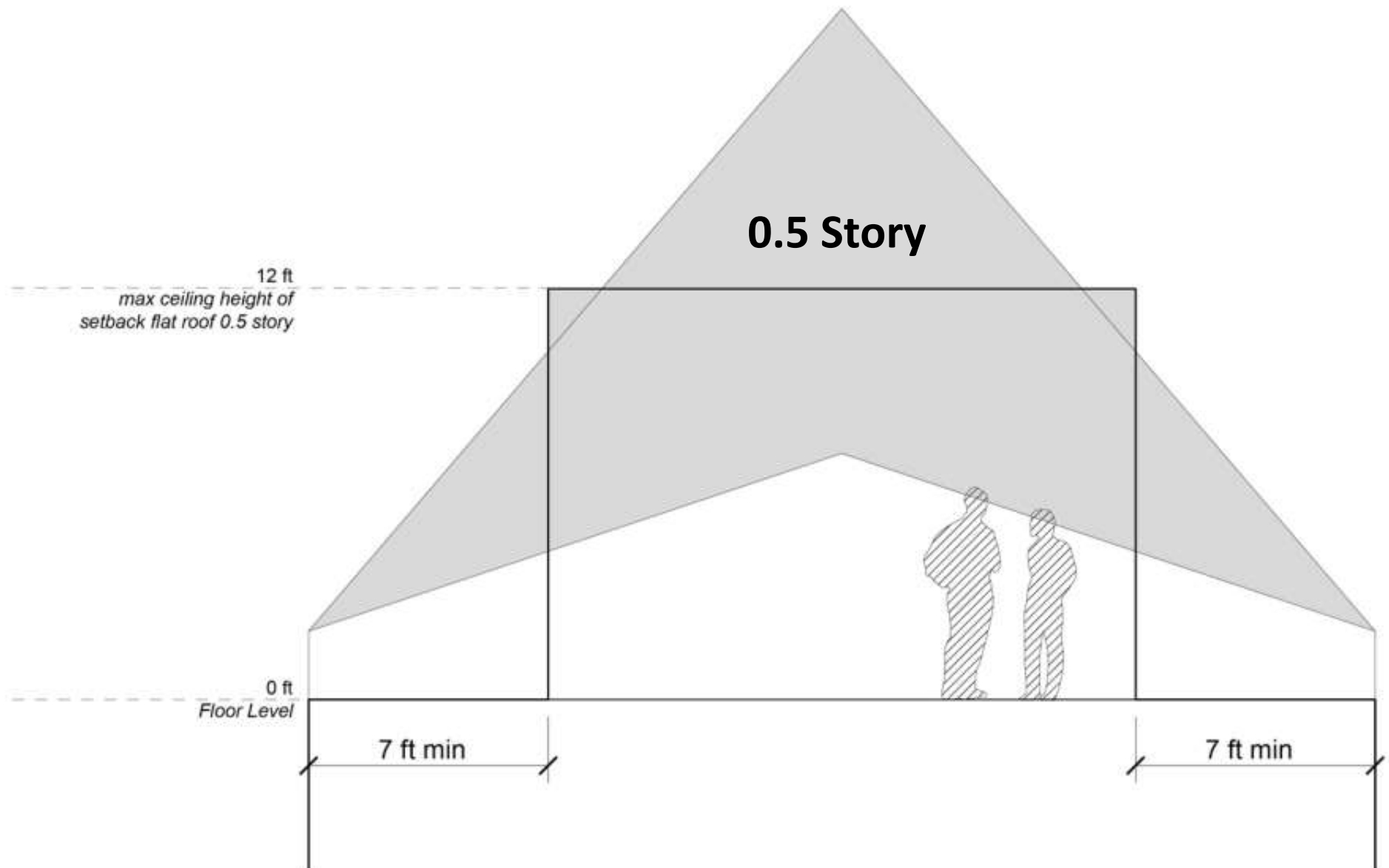

Solution B

Modify regulations so that they allow for a variety of design styles

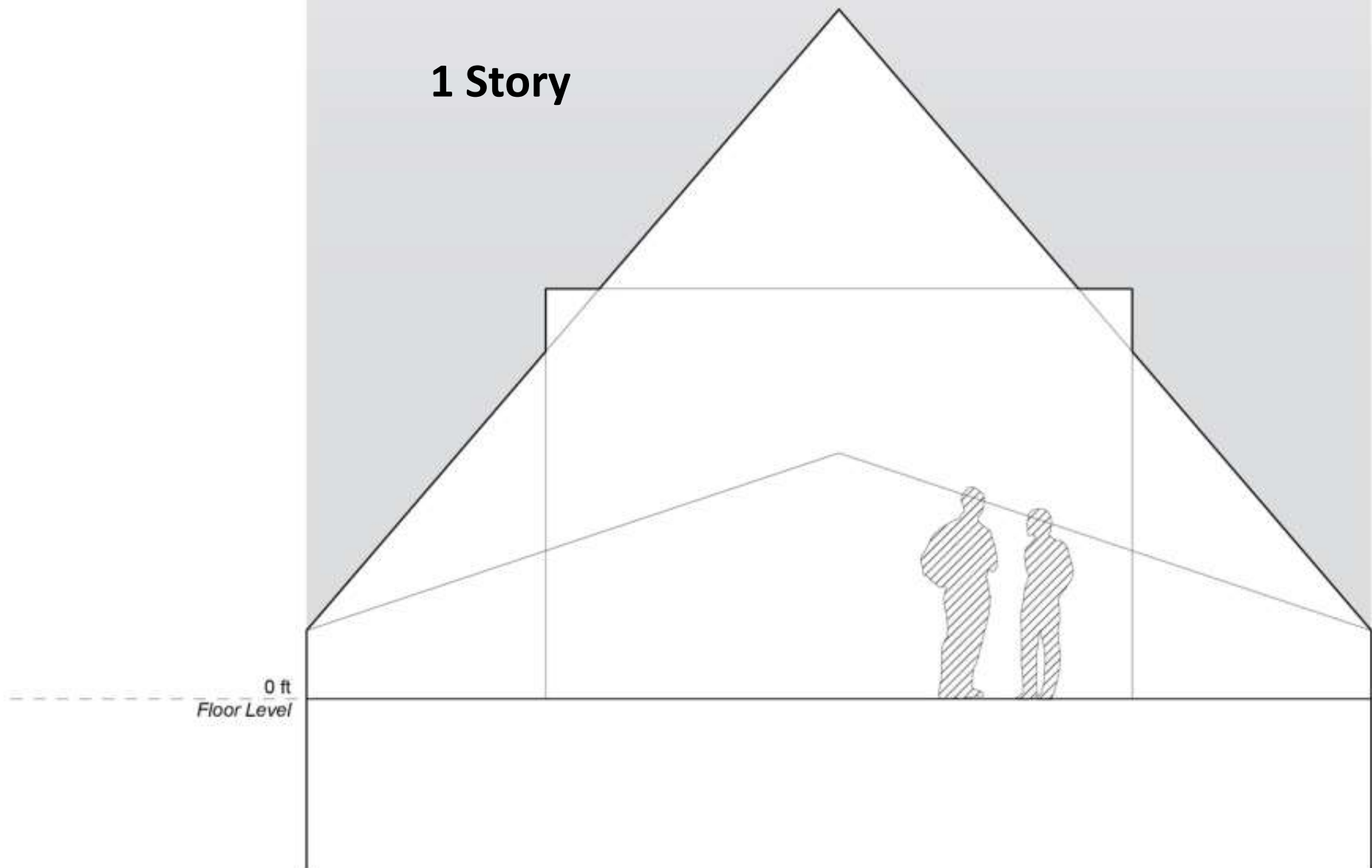

Solution B

Building Components should be named generically

Turret →
Corner Bay
Window



Problem C

Building Type footprint increase allowed by special permit

Building Type	By-Right Building Footprint Max. Square Feet	Special Permit Building Footprint Max. Square Feet
A	2,400	3,000
B	1,400	2,000
C	1,200	1,800
D	3,500	4,000
Two-unit	2,000	2,200
3-Unit	1,600	1,800
Townhouse Section	1,500	1,800
4-8 Unit	2,500	N/A

Solution C

Remove Building Type footprint increases by Special Permit and add new Building Components that allow for similar flexibility

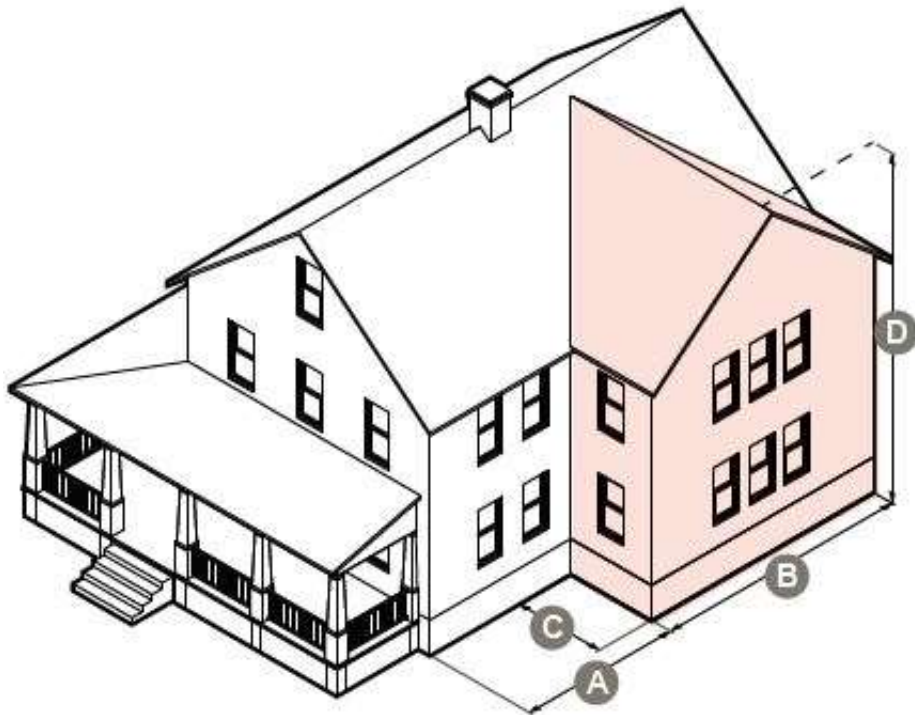

Side Wing

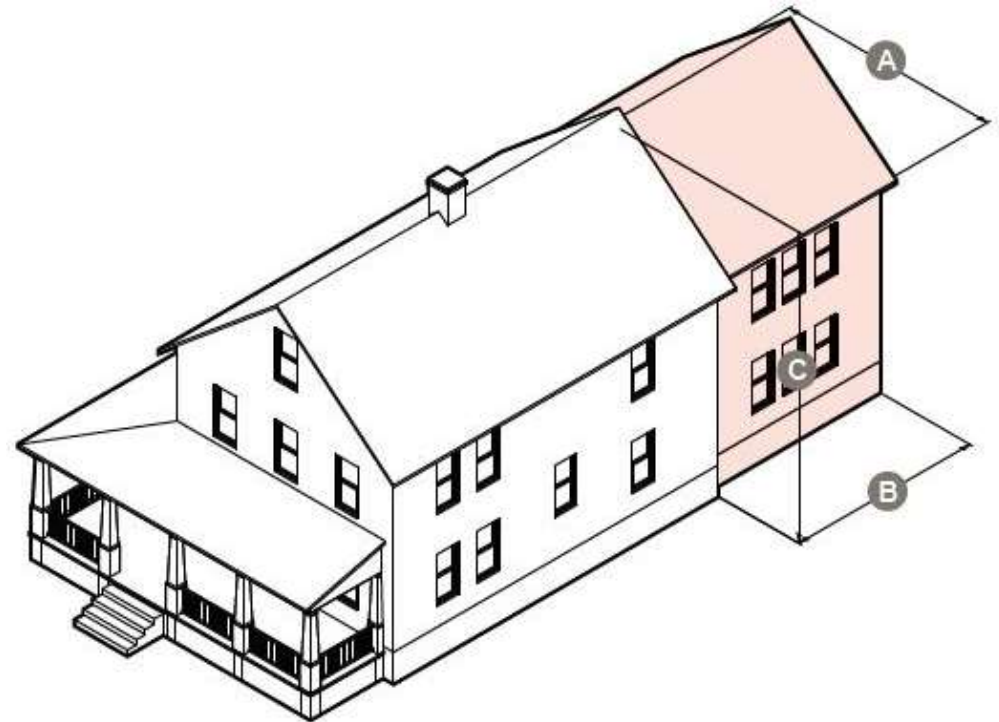

Rear Addition

Discussion: Building Components



Part III: Responses to Councilor questions (5/ 19)

Goals

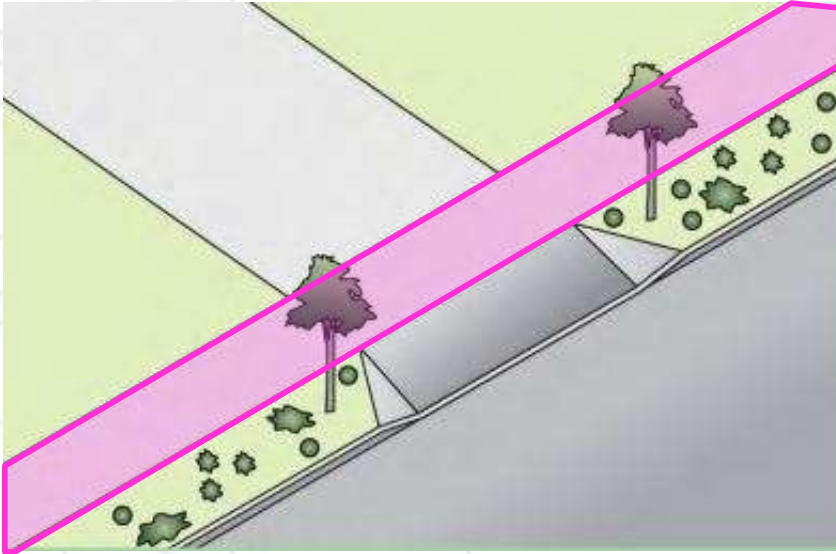

- **Safety**
- **Sustainability**
- **Quality Design**





Question

What are the sources of the draft language being used for the garage and driveway standards?

Multiple Sources

- **Utile (consultant)**
- **ISD, Engineering, Current Planning (internal staff)**
- **Local Architects/Builders**
- **Other City Zoning Codes**

Question

How was 10 feet determined for the width of driveways for residential properties with eight units or less (sec. 3.7.1.E5)?

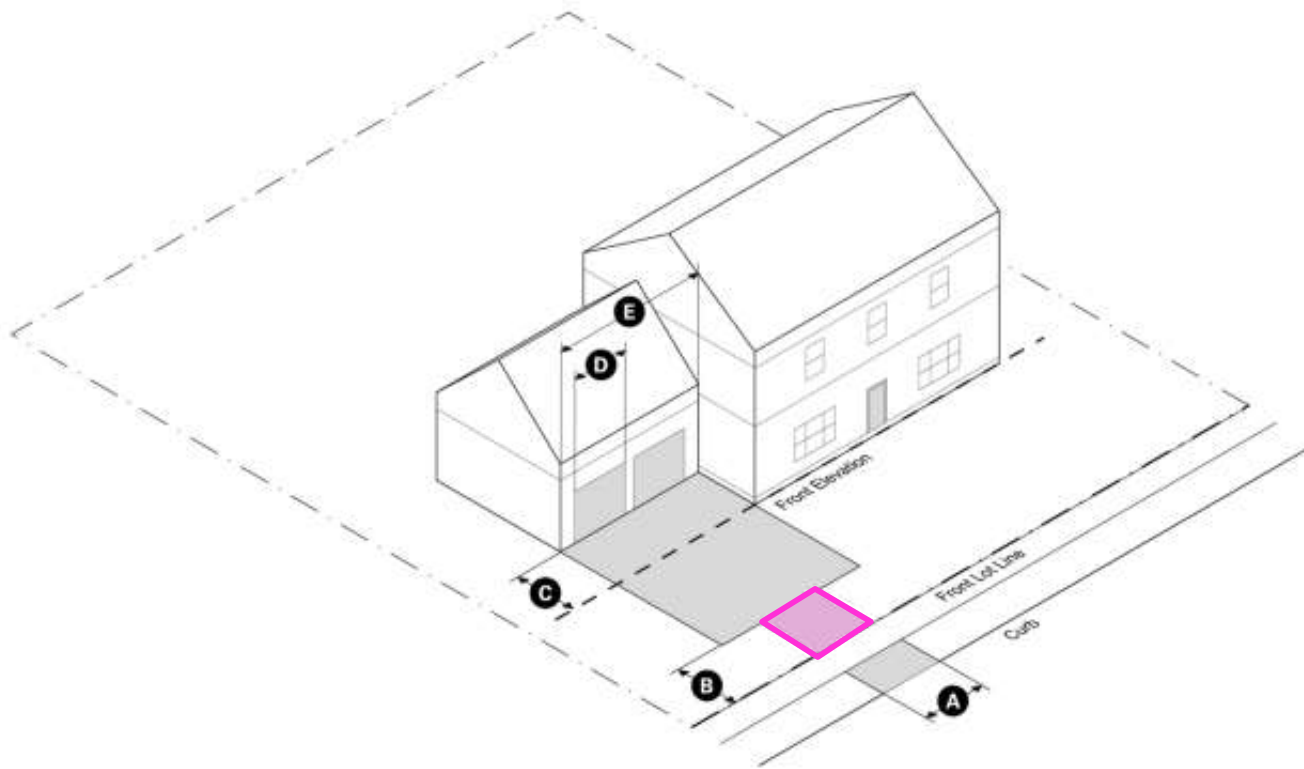

Single-Family Front-Facing Garage

A	Width (max)	10 ft
B	Distance (min)	10 ft
C	Distance (min)	10 ft
D	Width (max)	9 ft
E	Width (max)	50% of total front facade

Design Standards

The curb cut is limited in width and the driveway apron must be set back from the front of the lot.

The face of the garage must be set back from the front elevation and garage doors must be separate and not exceed a certain width.

Question

How will the new regulations impact snow removal?

- **Typical snowplows are between 6.5-8ft wide (less than driveway maximum)**
- **Salt can be used with pervious pavement (not sand)**
- **Snowplows can be used on pervious pavement (blade shoes)**
- **Speaking with local snow removal companies for additional guidance**

Question

What are grass pavers, pervious concrete and porous asphalt (sec. 3.7.1.E1)?



Grass Pavers



Porous Concrete

Question

What is the relative cost of installing and maintaining traditionally paved driveways vs. pervious systems?

- **Pervious systems cost 20-25% more than traditional asphalt**
- **Regular maintenance is required**
- **Other benefits outweigh the additional cost**

Question

How was 35 feet between two curb cuts determined (3.7.1.E7)?

- **Curb cuts reduce on-street parking and should be minimized**
- **If a property has two curb cuts, requiring 35 feet between each:**
 - **Allows for 2 on-street parking spaces between them**
 - **Reduces broken up sections of sidewalk**

Question

The 6-8 Salisbury Rd case study looked incorrect. Did the garages exceed 50% of the Front Elevation of the building (sec. 3.4.2.F.1)?

	Existing Project	Modified
Building Width	67 ft	67 ft
Garage Width	40 ft	33.5 ft

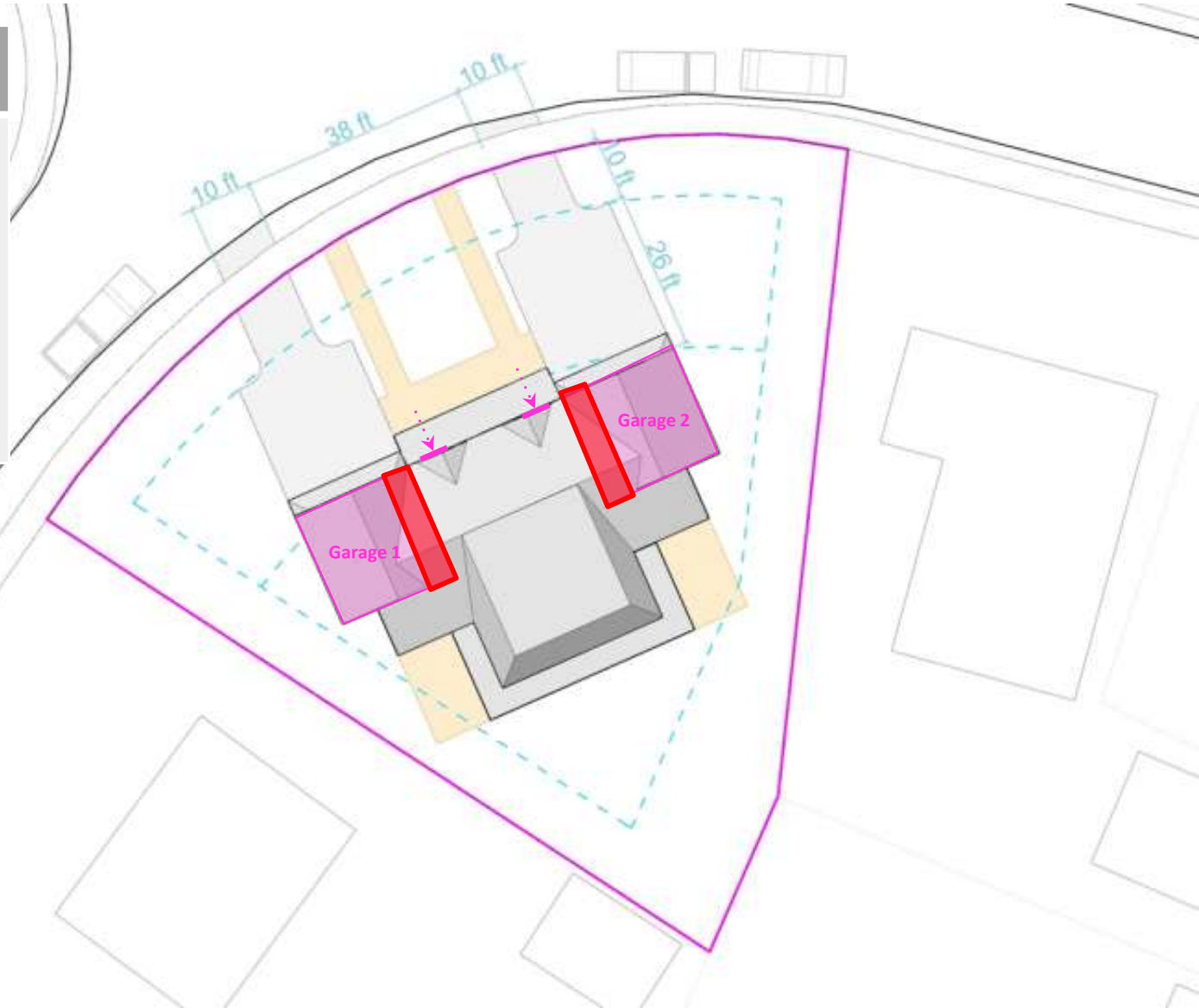

Question

The 6-8 Salisbury Rd case study looked incorrect. Did the garages exceed 50% of the Front Elevation of the building?





Question

Sec. 3.7.1.E4 parking stall requirements - is this just for new builds? Presently many homes in my neighborhood would be non-conforming.

- **Existing properties that are non-conforming with the proposed regulations would be able to maintain that non-conformity**
- **Renovations, to other parts of the property, would not be impacted**
- **New development would need to fully comply**

Question

Why are properties within R1 districts set back more than 70 feet from the Primary Front Lot Line exempt (sec. 3.4.2G) from Garage Design Standards?

- **Purpose of the regulation is to limit the impact garages have on the street and surrounding neighborhood**
- **Homes set back 70 feet or more inherently have a much lower visual impact**

Question

Why are properties within R1 districts set back more than 70 feet from the Primary Front Lot Line exempt (sec. 3.4.2G) from Garage Design Standards?

- **Purpose of the regulation is to limit the impact garages have on the street and surrounding neighborhood**
- **Homes set back 70 feet or more inherently have a much lower visual impact**



Question

Why do you allow side-facing and rear-garages on narrow lots? Shouldn't they be allowed on all lots? What constitutes a 'narrow lot'?

- **Side-facing and rear-facing garages are allowed on all lots**
- **These garage types provide alternatives to front facing garages to narrow lots in particular**
- **'narrow lot' is not a defined term within the draft ordinance**



Next Steps & Schedule



Next Steps

6/3- Professional Focus Group

6/8 at ZAP- Office Hours

6/15 at ZAP- Uses, Parking, Alternate Lot Configurations

Homework

Will be provided in the next ZAP memo

Thank You!

